



Designed in the U.S.A

OmegaLuxTM SOLAR STREET LIGHT

Hurricane Resistant



OmegaLuxTM 
Designed in the U.S.A.

Hurricane Resistant Integrated Solar Street Light

Designed and engineered in the USA, the pinnacle of solar lighting design. Omegalux is crafted with a robust and ultra-thick casing, this solar light is built to withstand extreme winds and resist the harsh effects of salty corrosion. Its sleek and modern appearance enhances the aesthetics of any setting while delivering unparalleled durability. Omegalux is versatile, perfect for parking lots, squares, residential areas, walkways, and bike paths, especially in coastal regions or islands where resilience is paramount. For enhanced reliability, it offers a hybrid 220V and solar-powered version, ensuring uninterrupted performance.

Engineered for premium projects, Omegalux combines cutting-edge technology with exceptional design, providing unmatched functionality and elegance. Elevate your lighting projects with a solution that's as tough as it is beautiful.

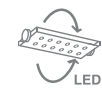

AUTO-GEAR
ANGLE LOCK

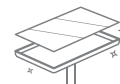

ALU-DIE CAST
HOUSING



MOTION
SENSOR



STAINLESS
STEEL 304



EXTREME WIND
RESISTANCE

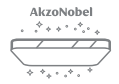

AlkoNobel
MARINE GRADE
ANTI-CORROSION

Die-Cast Aluminum Housing

The lamp body is constructed from premium die-cast aluminum, blending sleek aesthetics with uncompromising strength. This design not only enhances heat dissipation but also ensures long-term durability, maintaining the product's integrity even in extreme weather conditions.

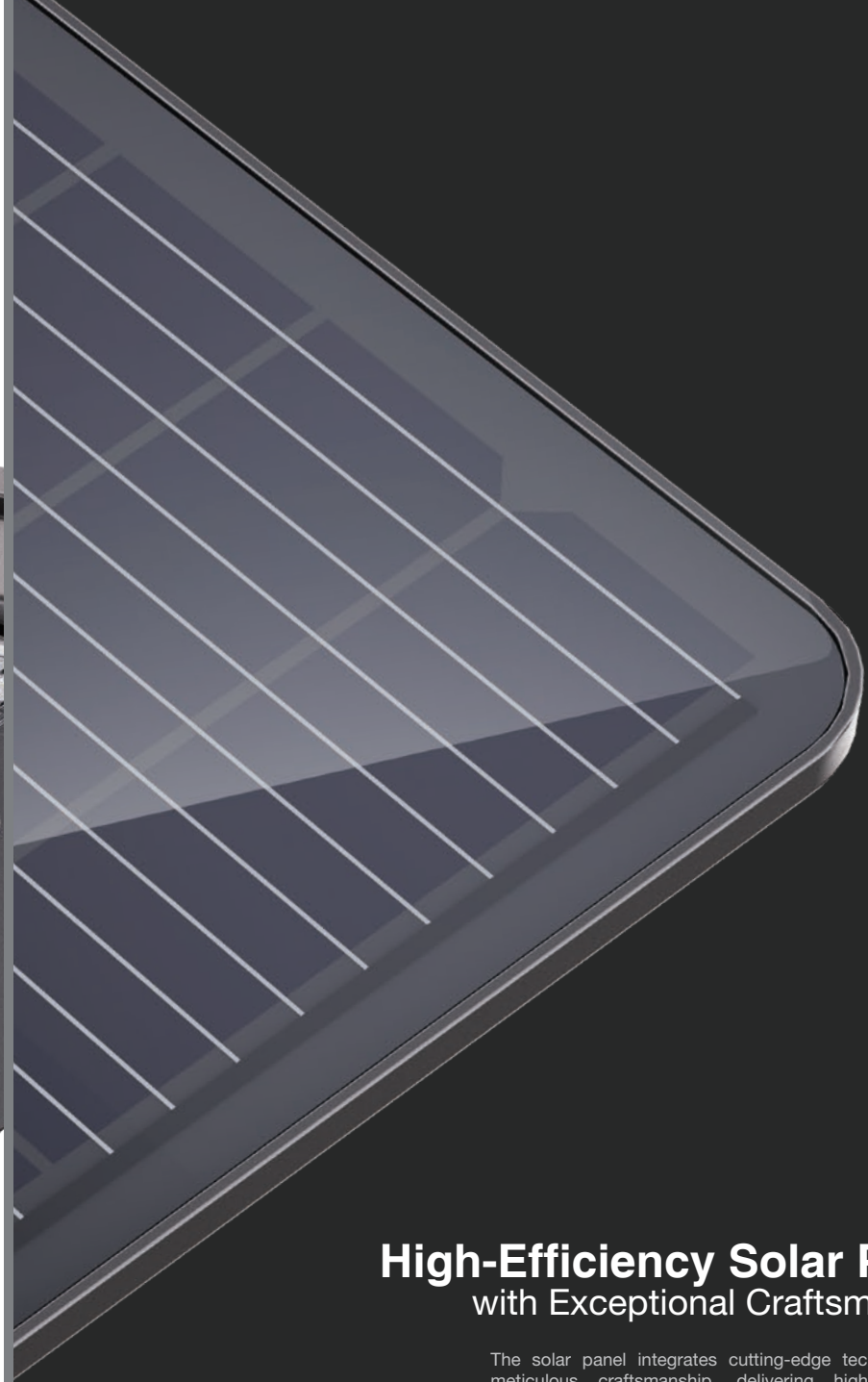

High-Efficiency Solar Panel with Exceptional Craftsmanship

The solar panel integrates cutting-edge technology with meticulous craftsmanship, delivering high conversion efficiency. Its innovative design ensures maximum energy generation, even under less-than-ideal sunlight conditions, making it a top-tier solution for sustainable lighting needs.



304 Stainless Steel Adjustable Bracket

This solar street light is equipped with a robust 304 stainless steel bracket featuring a precision-engineered adjustable joint. Designed for superior durability and flexibility, it ensures optimal positioning to maximize sunlight absorption, while offering exceptional resistance to corrosion and wear—perfect

Adjustable-Angle LED Module

Featuring a fully rotatable LED module, this light ensures precise and efficient illumination tailored to diverse applications. Combined with high-lumen output and advanced optics, the design optimizes lighting distribution for enhanced uniformity and reduced energy waste.



LED Optics Optional

Our street lights feature a variety of advanced optical lens types, each carefully designed to maximize their unique advantages. By optimizing the distribution of light energy, these lenses can also significantly improve the utilization rate of light energy, reduce energy consumption, extend the service life of street lights, and bring more efficient, environmentally friendly and economical solutions to your road lighting projects.

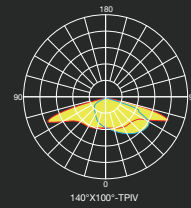
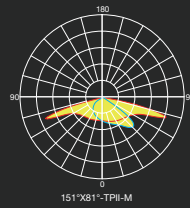
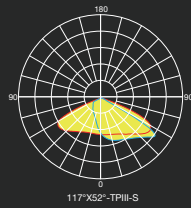
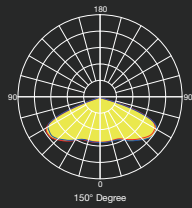
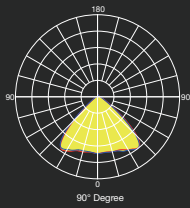
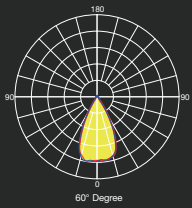

PRODUCT PARAMETERS



Single LED Module



Dual LED Module

Product Size

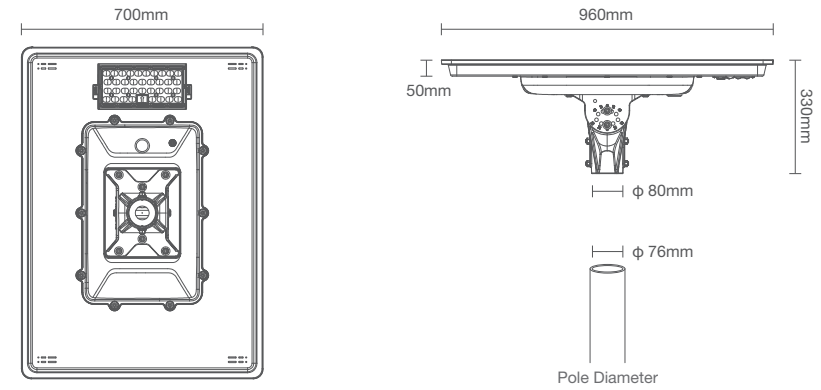

Default Lighting Profile

Our solar streetlight controller features a unique function that adjusts to winter or summer conditions based on nighttime duration. In winter, it activates energy-saving mode to extend battery life and ensure all-night lighting. In summer, it switches to high-power mode for maximum brightness. This smart adjustment guarantees consistent performance year-round, ensuring reliable lighting while optimizing energy use. It's a practical and efficient solution for various environments and challenging conditions.

Summer Mode

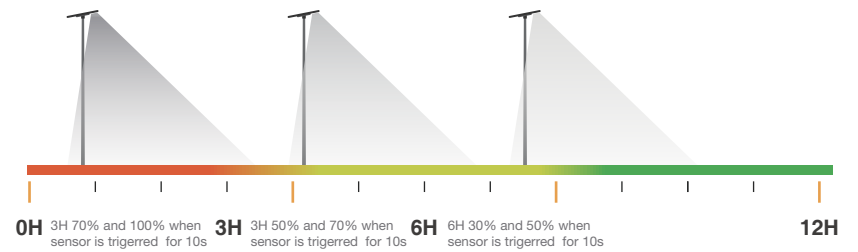

Winter Mode

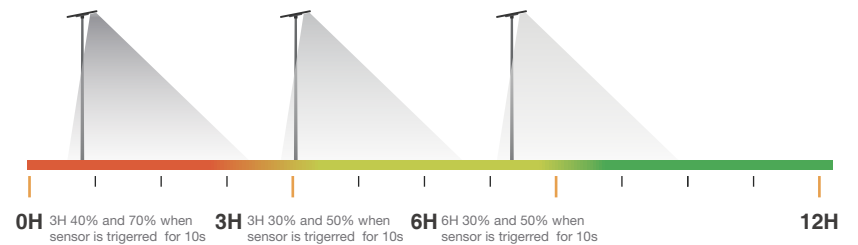

Model	AIO-80WS	AIO-100WS
Luminous Flux	13,600lm	17,000lm
LED Power	80W max	2*50W max
LED Chip	SMD5050 5W/LED	•
LED Quantity	36 pcs	72 pcs
LED Lifetime	75,000H	•
CRI	>78	•
CCT Range	2200K ~ 6000K	2200K ~ 6000K
LiFePO4 Battery	12.8V 45AH	12.8V 60AH
Battery Lifetime	4000 cycles @ D.O.D 60%	•
Solar Panel	128W 18V Mono	•
Solar Controller	MPPT	•
Motion Sensor	PIR / Microwave Optional	•
Dimension	960*700*330mm	•
Pole Diameter	76mm	•
Operating Temp.	-20°C ~ +60°C	•
Operating humidity	10% ~ 90%	•
Fixture materials	Aluminium Die Casting	•
Fixture color	Black	•
Installation Height	7~12m	•
IP Rating	IP66	•
Net Weight	29.30Kg	31.50Kg
Warranty	5 years	•



Wireless Smart Control System

Experience the next level of convenience with our Wireless Smart Control System for solar streetlights. This innovative technology enables seamless monitoring and management of solar streetlights via smartphones or computers. Effortlessly track real-time status, adjust lighting schedules, and optimize performance for entire groups of lights with just a few clicks.

Designed for efficiency and ease, the system reduces maintenance efforts by providing instant alerts for any issues, ensuring minimal downtime. Perfect for large-scale installations, it empowers users with complete control and adaptability, making solar streetlight management smarter, faster, and more efficient than ever before. Upgrade to intelligent lighting solutions today!

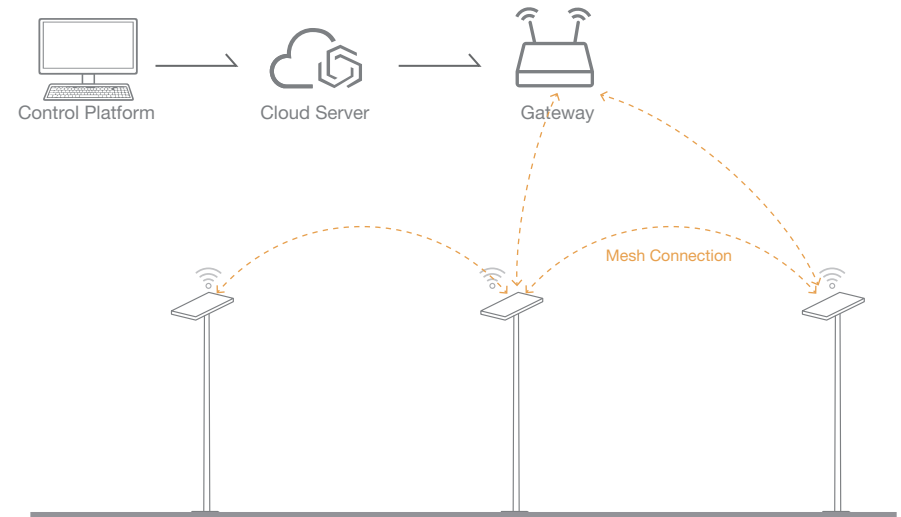

Hybrid System with Grid Power

The hybrid solar light system with AC power as backup is designed to make the solar lights more smarter and more reliable in very challenge conditions especially the area where the solar radiation is not stable and strong all the year round. The system automatically monitors the battery voltage and will switch between solar power and 220V grid electricity, so the lights will be functional well no matter the weather is good or not.

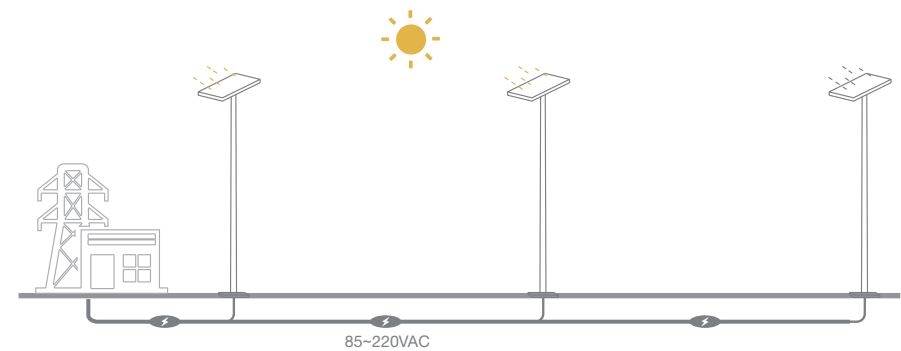



Designed in the U.S.A

OmegaLux™

SOLAR STREET LIGHT

Hurricane Resistant



LiFePO4
Battery



Intelligent
Control



High brightness
LED

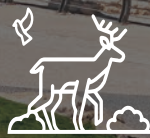

Biodiversity
Protection



IP65
Waterproof



Designed
Aesthetically



Remote
Control



Hybrid function
(Solar & Grid)