

## SOLAR LED INTEGRATED COMMERCIAL AREA LIGHT

Project: \_\_\_\_\_

Type: \_\_\_\_\_

Quantity: \_\_\_\_\_

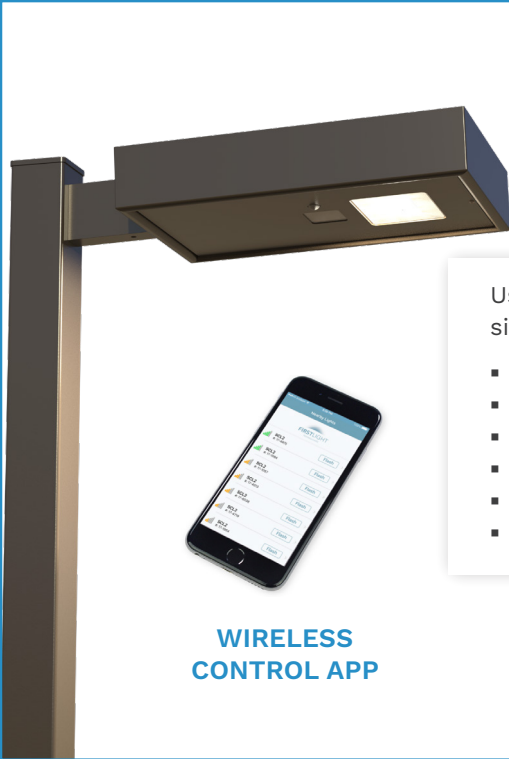

**WIRELESS  
CONTROL APP**

The SCL2 Series solar LED luminaire is a great fit for commercial, parking lot, recreational bikeway/pathway and public space lighting applications. The self-contained, unobtrusive design integrates its solar power, adaptive control and LED technologies into a compact and efficient form. With robust construction and unequalled performance, the SCL2 series is an excellent fit wherever cost effective, full cutoff lighting is required.

Using solar power and LEDs, the SCL2 series is completely self-contained and offers significant benefits:

- Cost effective design ships fully assembled and installs in minutes
- Smart Connect provides wireless control & communication with your light
- Low installation cost and minimal site impact with no trenching, cabling or wiring
- Minimal ongoing costs with no electrical bills or bulbs to change
- Operates entirely independent from the grid and is immune to power outages
- A sustainable choice without recurring carbon emissions

All of our solar powered lights are enabled by our innovative Solar Lighting Controller (SLC). The SLC in each light is “self-learning” and allows the lights to predictively adapt to their surroundings, providing a level of lighting performance and reliability unavailable in other solar lighting products.

## TECHNICAL SPECIFICATIONS

- Solar Module:**
- High-efficiency monocrystalline cells
  - Inconspicuously integrated into the top of luminaire
  - Used for day/night detection (no photocell required)

- Solar Lighting Controller (SLC):**
- Microcontroller-based technology
  - High-efficiency, Maximum Power Point Tracking (MPPT) battery charger
  - Built-in high-efficiency LED driver
  - Multiyear data logging
  - Automatically manages lighting performance based on environmental conditions and lighting requirements
  - Integrated into luminaire housing

- Battery:**
- High performance lithium (LiFePO<sub>4</sub>)
  - Exceptional 8 – 10 year lifecycle
  - High temperature tolerance
  - Contained within luminaire housing
  - Designed for easy battery changes when required

- LEDs and Optics:**
- 100,000 hour L70 lifetime LED
  - Warm (3000K) and neutral (4000K) white color temperatures available
  - High-efficiency type 2, 3, 4 and 5, full cutoff optics
  - Typical lumen output from 2696 to 2930 lumens

- Mechanical Construction:**
- Extruded and formed, low copper aluminum enclosure and mounting arm
  - Stainless fasteners with security fastener option
  - Architectural grade, super durable, TGIC powder coat
  - Four standard colors with custom colors available

- Factory Set Lighting Profiles:**
- 11 standard duration profiles available
  - Real-time lighting profile options available
  - See lighting profile sheet for all options
  - Lighting profiles and motion sensing options are field configurable with app
  - Motion sensing capabilities optimize performance based on usage

- Wireless Controls:**
- Easy-to-use interface via iOS smartphone app
  - Configure and control lighting profiles
  - Adjust dusk and dawn thresholds
  - Motion sensing capabilities optimize performance based on usage

EPA: 0.99ft<sup>2</sup> (0.09m<sup>2</sup>)

Weight: 34 lbs (15.4kg) including battery

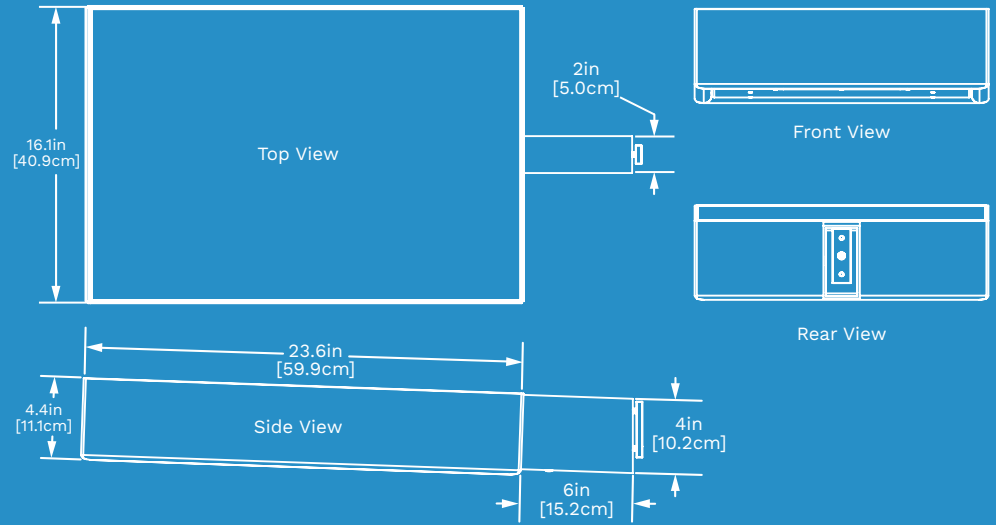
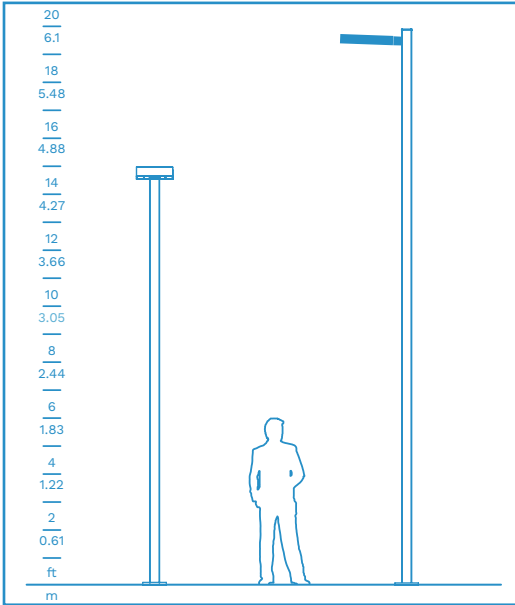

### PHOTOMETRICS (IES files available on our website)

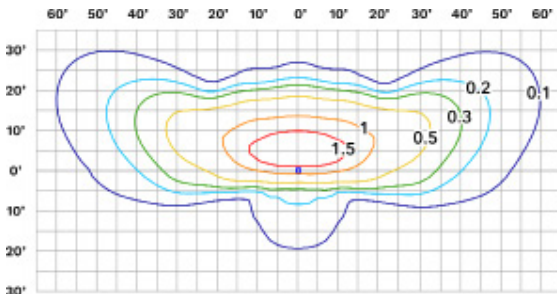

**Type 2**

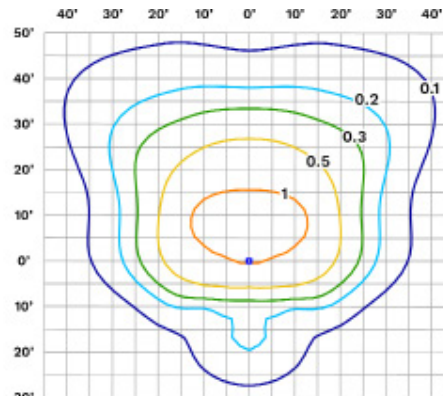

**Type 4**

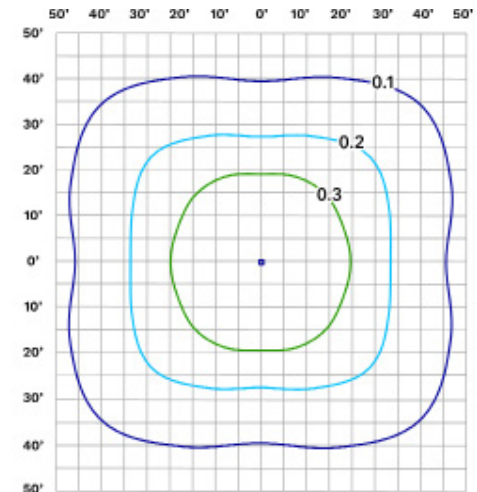

**Type 5**

- Notes**
- Photometrics based on 20 ft mounting height
  - All light levels in foot candles (fc) with 4500K color temperature and 2655 lumen output
  - To convert to lux multiply light level by 10.7
  - Contact FLT for help choosing the right lighting profile
  - Motion sensing is ON by default
  - Specifications subject to change without notice

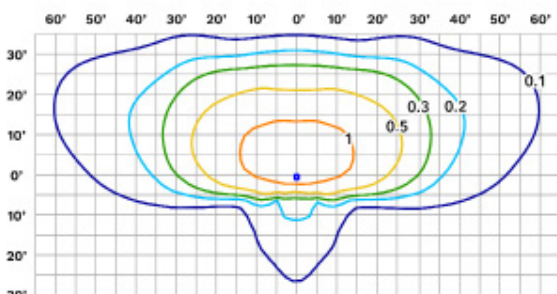

**Type 3**

### ORDER MATRIX



Series	Mounting	Finish	Distribution	LED Color	Lighting Profiles (See Profile Sheet)	Options
SCL2	SPMS - Side Pole Mount Square	BK - Black	T2 - Type 2	WW - 3000K	00 - Dusk till dawn	SEC - Security Fasteners
	SPMR - Side Pole Mount Round	BZ - Bronze	T3 - Type 3	NW - 4000K	09 - On at dusk, 100% for 3 hours, dim to 30%, brighten to 100% one hour before dawn, off at dawn (DEFAULT)	MSO - Motion Sensor Off
	NMNT - No Mount	SV - Silver	T4 - Type 4			
		WH - White	T5 - Type 5			
		CC - Custom			TX0000 - On at dusk until time between 1800 & 0600. X = O (Off) or D (Dim). 0000 = time to dim or turn off.	