

Solar Airfield Guidance Signs

Flash Technology solar LED airfield guidance signs are a simple solution for airfields that experience difficulties with grid access or for those that require a quick, minimally-disruptive addition to an existing airfield.

- Includes a solar-powered sign and a solar engine power supply (SEPS)
- SEPS incorporates the latest technology in solar technology, hardware and software to provide a reliable and sustainable power source.
- High-quality LED light source virtually eliminates runway shutdowns, reduces re-lamping expenses and on-going maintenance costs.
- Battery life of 5+ years
- Easy installation and relocation—no specialized work crews required
- Limited air traffic disruption and functions immediately upon installation
- Optional Handheld Controller allows for remote, wireless operation for enhanced visibility in poor weather conditions.
- 7+ days of autonomy (operation without solar charging)—scalable to meet requirements up to 40 days



Construction

Corrosion-resistant sign construction requires minimal maintenance:

- Aluminum housing
- Acrylic sign legend panels
- Stainless steel hardware, retroreflective sheeting

Installation

- Each sign ships with fragile couplings and floor flanges-ready for installation on a concrete pad (recommended installation method).
- The SEPS should be installed on a level concrete pad within 20 feet of the solar sign.
- For a temporary application, the wiring between the SEPS and the sign can be above ground. Both the sign and SEPS contain side conduits for cabling access.

MODELS			
Type	Purpose	Legend Color	Background
L-858Y	Direction, Destination & Boundary	58.6" (149 cm)	Yellow
L-858R	Mandatory Sign	71.6" (182 cm)	Red
L-858L	Runway/Taxiway Location	Yellow	Black
L-858B	Runway Distance Remaining	White	Black

SPECIFICATIONS	
Compliance	FAA: Meets L-858Y, L-858R, L-858L and L-858B per AC 150/5345-44 and Engineering Brief 67
	CE: Complies with EMC Directive 2004/108/EC
	ICAO: Please inquire about ICAO compliant options
Temperature	-40 °F to +131 °F (-40 °C to +55 °C)
Humidity	1-100%
Wind	Mode 2 signs withstand wind velocities up to 225 mph

Airfield Guidance Signs

SIGN HEIGHTS

Type	Size Number	Face Height	Legend Height	Mounting Height
L-858Y/R/L	1	18" (45.7 cm)	12" (30.5 cm)	29.7" (75.5 cm)
L-858Y/R/L	2	24" (61 cm)	15" (38.1 cm)	35.7" (90.8 cm)
L-858Y/R/L	3	30" (76.2 cm)	18" (45.7 cm)	41.7" (106 cm)
L-858B	4	48" (122 cm)	40" (101.6 cm)	58.2" (147.8 cm)
L-858B	5	30" (76.2 cm)	25" (63.5 cm)	41.7" (106 cm)

SIGN LENGTHS

Number	1 Module	2 Module	3 Module	4 Module
1	29.4" (75 cm)	58.6" (149 cm)	87.9" (223 cm)	117.2" (298 cm)
2	35.9" (91 cm)	71.6" (182 cm)	107.4" (273 cm)	143.2" (364 cm)
3	42.4" (108 cm)	84.6" (215 cm)	126.9" (323 cm)	169.2" (430 cm)
4	47.9" (122 cm)	n/a	n/a	n/a
5	42.4" (108 cm)	n/a	n/a	n/a

Note: Sign depth is 9.4" (23.9 cm)

CONFIGURATION

Type	Size	Module	RF Control	Face
L-858Y	1	1		
L-858R	2	2	RF	Single
L-858L	3	3	NA	Double
L-858B	4	4		

LED DRIVER

Channel A	18-38 VDC from 0.3-1.4 A 5-100% duty cycle, constant current
Channel B	18-38 VDC from 0.3-1.4 A 5-100% duty cycle, constant current
Automatic Light Control (ALC)	When enabled, automatically adjusts to low levels of sunlight to ensure continued autonomous operation Available on channels A and B
Control, Autonomous Mode	Dusk-to-dawn, steady-on
Load Cabling	22' (6.7 m) cable can exit onto the surface or down into a ground pot

PV PANEL

Power	95 W
Type	High-efficiency monocrystalline, IEC 61215
Lifetime	10 years at 90% output

WIRELESS

Range	2.5 miles (4 km)
Frequency	900 MHz ISM Band, FHSS
Encryption	256-bit AES
Control, Ondemand Mode	Seamless integration with existing Flash Technology wireless solar products Up to 8 independent groups Flash, emergency, autonomous, ondemand temporary, configuration and ARCAL modes



SEPS SPECIFICATIONS

Installed Weight	132 lbs (59.8 kg)
Shipping Weight	Box 1 (SEPS): 76 lbs (34.4 kg)
	Box 2 (battery): 68 lbs (30.8 kg)
Installed Dimensions	42.9 x 29.9 x 17.4" (108.9 x 75.9 x 44.1 cm) With wireless antenna at 55° tilt
Shipping Dimensions	Box 1 (SEPS): 46.9 x 25.5 x 14" (119.1 x 64.7 x 35.6 cm)
	Box 2 (battery): 13.1 x 8.3 x 7.4" (33.2 x 21 x 18.8 cm)
Temperature	Operating: -22 to +122 °F (-30 to +50 °C)
	Storage: -40 to +176 °F (-40 to +80 °C)
Type	Replaceable and recyclable
	Absorbent glass mat (AGM) SLA
	Standard with 1 battery
Lifetime	4,000 cycles to 20% depth of discharge at +68 °F (+20°C)
Charger	Temperature-compensated, maximum power point tracking (TC-MPPT)

SEPS DIMENSIONS

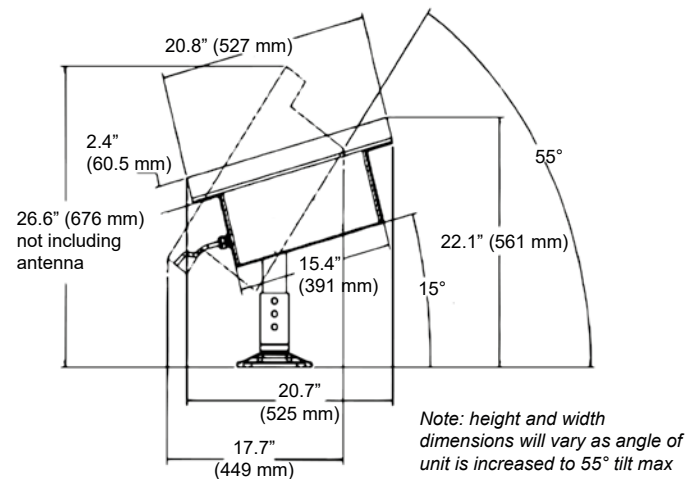

PACKAGING DATA

Signs are shipped with frangible couplings and floor flange-ready for installation.

Description	Gross Weight	Dimensions
Size 1	Module 1	46 lbs (21 kg) 34 x 34 x 13" (87 x 86.4 x 33 cm)
	Module 2	78 lbs (35 kg) 34 x 63 x 13" (87 x 160 x 33 cm)
	Module 3	115 lbs (52 kg) 34 x 92 x 13" (87 x 234 x 33 cm)
	Module 4	169 lbs (77 kg) 34 x 121 x 13" (87 x 307 x 33 cm)
Size 2	Module 1	71 lbs (32 kg) 40 x 40 x 13" (102 x 102 x 33 cm)
	Module 2	104 lbs (47 kg) 40 x 76 x 13" (102 x 193 x 33 cm)
	Module 3	153 lbs (70 kg) 40 x 112 x 13" (102 x 285 x 33 cm)
	Module 4	220 lbs (100 kg) 40 x 147 x 13" (102 x 374 x 33 cm)
Size 3	Module 1	81 lbs (37 kg) 46 x 46 x 13" (117 x 117 x 33 cm)
	Module 2	131 lbs (60 kg) 46 x 89 x 13" (117 x 226 x 33 cm)
	Module 3	199 lbs (90 kg) 46 x 131 x 13" (117 x 333 x 33 cm)
	Module 4	252 lbs (114) 46 x 173 x 13" (117 x 440 x 33 cm)
Size 4	Module 1	120 lbs (54 kg) 62 x 52 x 13" (158 x 132 x 33 cm)
Size 5	Module 1	85 lbs (39 kg) 46 x 46 x 13" (117 x 117 x 33 cm)

FLASH TECHNOLOGY

flashsales@spx.com | flashtechnology.com/airfield | 1.615.503.2000

©2019 Flash Technology. All rights reserved. Data and specifications subject to change without notification. ISO 9001:2015. DAFGS-01 Rev A